

# **StuckyNet-Link**

The Internet Solution for Asset-Based Lenders

by William Stucky & Associates, Inc.

## **Overview**

- StuckyNet-Link is the Internet Solution for Asset-Based Lenders. Borrowers are able to send information securely via the Internet. Lenders are able to automatically update the Stucky NT\ABL, WinABLM, or Nova\Commercial Loan System.
  - On-line reporting
  - Replace overnight packages
  - Increase efficiency
  - Reduce clerical errors and labor

## **Features of StuckyNet-Link**

- StuckyNet-Link operates in conjunction with Stucky NT\ABL, WinABLM, or Nova\Commercial Loan System.
- Borrowers are able to complete a borrowing base posting and send it to a lender securely via the Internet.
- Lenders are able to automatically update the borrowing base posting to the system upon reviewing and accepting it.
- Sales registers, collection registers, A/R agings, A/P agings, inventory listings and certificates, financial statements and all types of electronic files can be sent securely via the Internet.
- Borrowers have on-line access to their loan ledgers, status report, interest statements and ineligible reports.
- Ineligibles can automatically be calculated from an A/R aging that is in an electronic file format. A detailed ineligible report is produced and can be sent to the borrower.

## **Benefits for the Lenders**

- Offer on-line reporting to your borrowers; gain a competitive edge in the market.
- Increased efficiency - system will automatically update upon approval by the lender.
- Reduced clerical errors and labor - no re-keying the borrowing base into system.
- No overnight packages - information is sent securely via the Internet.
- Less paper to handle / less file storage - information can be saved electronically.
- Loan ledger, status report and ineligibles are available to borrowers on-line, collateral analysts will spend less time sending faxes or answering phone calls.

## **Benefits for the Borrowers**

- On-line access to current loan ledgers, status report, interest statements and ineligibles.
- Borrowing base posting, including advance request, are sent via the Internet.
- No over-night packages to prepare; less paper to handle; reduced shipping expenses.
- All supporting documentation, invoice registers, cash receipts registers, A/R agings, etc., can be sent electronically.

# StuckyNet-Link Borrower Website



Please log in to initiate your online banking session:

Client Code

Username

Password

Copyright 2006, WSA. All rights reserved.



The borrower interface is HTML based, eliminating the need to load software on the borrower's PC. The above screen is the web page the borrower will use to log in to StuckyNet-Link.

# Loan Status



Data last updated: Mar 13 2006 09:49:04 (PST) [Privacy Policy](#) | [Contact Us](#) | [Help](#)

[Change Password](#) [Log Off](#)

[Borrowing Base History](#)
[Borrowing Base Posting](#)
[Ineligible Report](#)
[Ineligible History](#)
[Interest Statement](#)
[Loan Ledger Report](#)
**[Loan Status Report](#)**
[Upload Files](#)
[Upload History](#)

## Loan Status

Client: SPTI Date: 3/31/06

Loan #	Type	Curr.	Rate	Gross Collateral	Ineligible	Reserve	Loan Limit	Net Collateral	Loan Balance	Availability
SPTI11	AR	USD	80.00%	2,496,593.90	2,146,533.32	100,000.00	10,000,000.00	180,048.46	156,771.38	23,277.08
SPTI21	IN	USD	60.00%	1,431,368.91	123,456.00	0.00	2,500,000.00	784,747.74	0.00	784,747.74
SPTI31	AR	USD	0.00%	0.00	0.00	0.00	0.00	0.00	100,000.00	0.00
<b>(USD) Total:</b>				3,927,962.81	2,269,989.32	100,000.00	12,900,000.00	964,796.20	256,771.38	708,024.82

The borrower can view their loan status report on-line and can print the report. Information can also be copied and pasted into Excel or Word.

# Loan Ledger



Data last updated: Mar 13 2006 09:49:04 (PST)

[Privacy Policy](#) | [Contact Us](#) | [Help](#)

[Change Password](#) | [Log Off](#)

<a href="#">Borrowing Base History</a>	<a href="#">Borrowing Base Posting</a>	<a href="#">Ineligible Report</a>	<a href="#">Ineligible History</a>	<a href="#">Interest Statement</a>	<b><a href="#">Loan Ledger Report</a></b>	<a href="#">Loan Status Report</a>	<a href="#">Upload Files</a>	<a href="#">Upload History</a>
--	--	-----------------------------------	------------------------------------	------------------------------------	---	------------------------------------	------------------------------	--------------------------------

## Loan Ledger

[Print](#)

**Loan: SPT111 Activity Dates: 3/01/06 to 3/31/06**

**Type: AR Currency: USD**

Date	Assn#	Coll#	Sales	Credits & Adjustments	Gross Collections	Collateral Balance	Advances	Adjustments	Net Cash	Loan Balance
Beginning Balances ----->						1,356,395.90				146,771.38
3/01/06	IntFr»	SPT111	0.00	0.00	0.00	1,356,395.90	0.00	10,000.00	0.00	156,771.38
3/07/06	03076	SN-07	836,548.00	0.00	0.00	2,192,943.90	0.00	0.00	0.00	156,771.38
3/07/06	030706	SN-07	236,549.00	87,180.00	26,549.00	2,490,123.90	0.00	0.00	0.00	156,771.38
3/13/06	031306	SN-13	23,654.00	(4,635.00)	12,549.00	2,496,593.90	0.00	0.00	0.00	156,771.38
<b>Totals:</b>			1,096,751.00	82,545.00	39,098.00	2,496,593.90	0.00	10,000.00	0.00	156,771.38

The borrower can view their loan ledger report on-line and can print the report. Information can also be copied and pasted into Excel or Word.

# Interest Statements



Data last updated: Mar 13 2006 09:49:04 (PST) [Privacy Policy](#) | [Contact Us](#) | [Help](#)

[Change Password](#) [Log Off](#)

<a href="#">Borrowing Base History</a>	<a href="#">Borrowing Base Posting</a>	<a href="#">Ineligible Report</a>	<a href="#">Ineligible History</a>	<b><a href="#">Interest Statement</a></b>	<a href="#">Loan Ledger Report</a>	<a href="#">Loan Status Report</a>	<a href="#">Upload Files</a>	<a href="#">Upload History</a>
--	--	-----------------------------------	------------------------------------	---	------------------------------------	------------------------------------	------------------------------	--------------------------------

## Interest Statement History

Date	Report
02/06	Int_SPTI0206.PDF
03/06	Int_SPTI0306.PDF

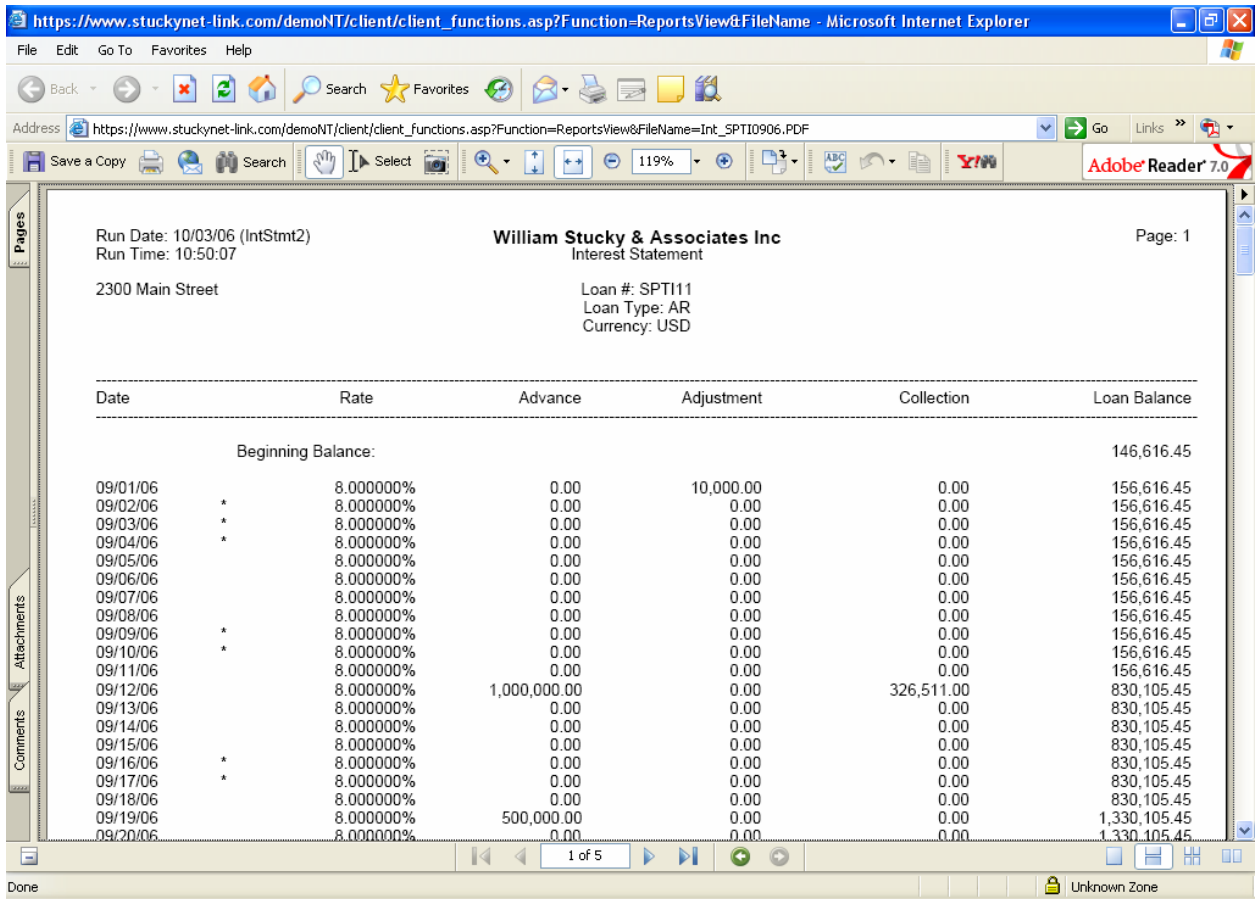

Run Date: 10/03/06 (IntStm2) Page: 1  
 Run Time: 10:50:07  
 2300 Main Street Loan #: SPTI11  
Loan Type: AR  
Currency: USD

Date	Rate	Advance	Adjustment	Collection	Loan Balance
Beginning Balance:					146,616.45
09/01/06	8.000000%	0.00	10,000.00	0.00	156,616.45
09/02/06	8.000000%	0.00	0.00	0.00	156,616.45
09/03/06	8.000000%	0.00	0.00	0.00	156,616.45
09/04/06	8.000000%	0.00	0.00	0.00	156,616.45
09/05/06	8.000000%	0.00	0.00	0.00	156,616.45
09/06/06	8.000000%	0.00	0.00	0.00	156,616.45
09/07/06	8.000000%	0.00	0.00	0.00	156,616.45
09/08/06	8.000000%	0.00	0.00	0.00	156,616.45
09/09/06	8.000000%	0.00	0.00	0.00	156,616.45
09/10/06	8.000000%	0.00	0.00	0.00	156,616.45
09/11/06	8.000000%	0.00	0.00	0.00	156,616.45
09/12/06	8.000000%	1,000,000.00	0.00	326,511.00	830,105.45
09/13/06	8.000000%	0.00	0.00	0.00	830,105.45
09/14/06	8.000000%	0.00	0.00	0.00	830,105.45
09/15/06	8.000000%	0.00	0.00	0.00	830,105.45
09/16/06	8.000000%	0.00	0.00	0.00	830,105.45
09/17/06	8.000000%	0.00	0.00	0.00	830,105.45
09/18/06	8.000000%	0.00	0.00	0.00	830,105.45
09/19/06	8.000000%	500,000.00	0.00	0.00	1,330,105.45
09/20/06	8.000000%	0.00	0.00	0.00	1,330,105.45

# Ineligibles



Data last updated: Mar 13 2006 09:49:04 (PST) [Privacy Policy](#) | [Contact Us](#) | [Help](#)

[Change Password](#) [Log Off](#)

<a href="#">Borrowing Base History</a>	<a href="#">Borrowing Base Posting</a>	<a href="#">Ineligible Report</a>	<b><a href="#">Ineligible History</a></b>	<a href="#">Interest Statement</a>	<a href="#">Loan Ledger Report</a>	<a href="#">Loan Status Report</a>	<a href="#">Upload Files</a>	<a href="#">Upload History</a>
--	--	-----------------------------------	---	------------------------------------	------------------------------------	------------------------------------	------------------------------	--------------------------------

## Ineligible History:

[Print](#)

**Loan: SPT111 Activity Dates: 12/08/05 to 3/31/06**

**Type: AR Currency: USD**

Date	Over 90 DAYS/CREDIT LIMIT	CROSS AGING RULE	CONCENTRATION RULE	CREDIT PAST DUE RULE	Contra	Foreign	Government	Affiliates	Other	Total
12/13/05	170,982.50	104,181.00	34,747.72	66.00	0.00	0.00	0.00	0.00	0.00	309,977.22
2/17/06	2,138,022.80	0.00	0.00	8,510.52	0.00	0.00	0.00	0.00	0.00	2,146,533.32

Date	TL			Total
12/13/05	100,000.00	0.00	0.00	100,000.00
2/17/06	100,000.00	0.00	0.00	100,000.00

The borrower can view the a history of the their ineligibles on-line and can print the report using the Browser or can view a detailed report generated in ARS.



Data last updated: Mar 13 2006 09:49:04 (PST) [Privacy Policy](#) | [Contact Us](#) | [Help](#)

[Change Password](#) [Log Off](#)

<a href="#">Borrowing Base History</a>	<a href="#">Borrowing Base Posting</a>	<b><a href="#">Ineligible Report</a></b>	<a href="#">Ineligible History</a>	<a href="#">Interest Statement</a>	<a href="#">Loan Ledger Report</a>	<a href="#">Loan Status Report</a>	<a href="#">Upload Files</a>	<a href="#">Upload History</a>
--	--	--	------------------------------------	------------------------------------	------------------------------------	------------------------------------	------------------------------	--------------------------------

## Ineligible Report

Loan #	Report
11	<a href="#">Detail</a>
11	<a href="#">Summary</a>

# Ineligibles

https://www.stuckynet-link.com/demoNT/client/client\_functions.asp?Function=ReportsView&FileName=Inel\_SPT111.PDF - Microsoft Internet Explorer

File Edit Go To Favorites Help

Address: https://www.stuckynet-link.com/demoNT/client/client\_functions.asp?Function=ReportsView&FileName=Inel\_SPT111.PDF

Save a Copy Search Select 91% Adobe Reader 7.0

Run Date: 11/03/06 (ARStnel)  
Run Time: 13:55:16

**William Stucky & Associates Inc**  
Ineligible Detail Report  
A/R Aging Date: 10/31/06  
Ineligibles As-Of-Date: 11/03/06  
Loan #: SPT111 (USD)

Page: 1

Debtor #	Name	A/R Balance	Ineligible	Credit Limit
<b>Ineligible 1 - Over 90 Days/Over Credit Limit</b>				
0001		22,547.12	2,098.00	0.00
0002		15,198.00	2,165.00	0.00
0005		197,118.00	73,850.00	0.00
0008		1,015.00	212.00	0.00
0011		115,190.36	2,300.00	0.00
0013		172,553.00	18,500.00	0.00
0021		43,419.00	1,255.00	0.00
0023		22,594.00	2,160.00	0.00
0024		29,444.00	14,803.00	0.00
0031		60,122.00	1,850.00	0.00
	<b>** Inel. Total</b>		<b>119,983.00</b>	
<b>Ineligible 2 - Cross Aging Rule</b>				
0005		197,118.00	123,268.00	0.00
0024		29,444.00	11,841.00	0.00
	<b>** Inel. Total</b>		<b>135,109.00</b>	
<b>Ineligible 3 - Concentration Rule</b>				
0032		249,550.00	34,747.72	0.00
	<b>** Inel. Total</b>		<b>34,747.72</b>	
<b>Ineligible 4 - Foreign</b>				
0003		32,323.83	32,323.83	0.00
	<b>** Inel. Total</b>		<b>32,323.83</b>	
	<b>** Grand Total</b>		<b>322,163.55</b>	

1 of 2

https://www.stuckynet-link.com/demoNT/client/client\_functions.asp?Function=ReportsView&FileName=Inel\_SPT111.PDF - Microsoft Internet Explorer

File Edit Go To Favorites Help

Address: https://www.stuckynet-link.com/demoNT/client/client\_functions.asp?Function=ReportsView&FileName=Inel\_SPT111.PDF

Save a Copy Search Select 91% Want to create online forms?

----- A/R Aging Spread -----

Total:	2,138,022.80	
0 - 30:	1,803,970.46	84.38%
31 - 60:	212,569.34	9.94%
61 - 90:	1,500.00	0.07%
91 - 120:	119,983.00	5.61%
Over 120:	0.00	0.00%

----- Ineligible Amounts -----

1. Over 90 Days/Credit Limit	119,983.00	37.24%
2. Cross Aging	135,109.00	41.94%
3. Concentration Rule	34,747.72	10.79%
4. Credit Past Due	0.00	0.00%
5. Other	0.00	0.00%
6. Foreign	32,323.83	10.03%
7. Other	0.00	0.00%
8. Other	0.00	0.00%
<b>**Total</b>	<b>322,163.55</b>	

----- High Concentration Debtors -----

Debtor#	Balance	
0032	249,550.00	11.83%
0005	197,118.00	9.22%
0025	180,000.00	8.42%
0013	172,553.00	8.07%
<b>**Total</b>	<b>798,221.00</b>	

2 of 2

# Borrowing Base Posting



Data last updated: Mar 13 2006 09:49:04 (PST) [Privacy Policy](#) | [Contact Us](#) | [Help](#)

[Change Password](#) [Log Off](#)

[Borrowing Base History](#)
[Borrowing Base Posting](#)
[Ineligible Report](#)
[Ineligible History](#)
[Interest Statement](#)
[Loan Ledger Report](#)
[Loan Status Report](#)
[Upload Files](#)
[Upload History](#)

## Borrowing Base Posting

Certificate #: test Client: SPTI  
 Date: 3/31/06 User: linda

Loan # - Type	11 / AR (USD)	21 / IN (USD)	31 / AR (USD)
Collateral Balance	2,496,593.90	1,431,368.91	0.00
Sales/Additions	<input type="text"/>	<input type="text"/>	<input type="text"/>
Credit Memos	<input type="text"/>	<input type="text"/>	<input type="text"/>
Adjustments	<input type="text"/>	<input type="text"/>	<input type="text"/>
Cash/Removals	<input type="text"/>	<input type="text"/>	<input type="text"/>
Discounts	<input type="text"/>	<input type="text"/>	<input type="text"/>
Non-AR Cash	<input type="text"/>	<input type="text"/>	<input type="text"/>
New Collateral Balance	2,496,593.90	1,431,368.91	0.00
Ineligibles	2,146,533.32	123,456.00	0.00
Advance Rate	80.00%	60.00%	0.00%
Reserves	100,000.00	0.00	0.00
Collateral Limit	10,000,000.00	2,500,000.00	0.00
New Net Collateral	180,048.46	784,747.74	0.00
Revolving Limit (USD)	12,900,000.00		
Total Line Limit (USD)	12,900,000.00		
Total Collateral (USD)	964,796.20		
Loan Balance	156,771.38	0.00	100,000.00
Advance Request	<input type="text"/>	<input type="text"/>	<input type="text"/>
DDA Account	<input type="text"/>	<input type="text"/>	<input type="text"/>
Collections	<input type="text"/>	<input type="text"/>	<input type="text"/>
New Loan Balance (USD)	256,771.38		
New Availability (USD)	708,024.82		

The borrower can complete the borrowing base posting on-line and submit it to the lender securely via the Internet.

# Upload Files

Data last updated: Mar 13 2006 09:49:04 (PST) [Privacy Policy](#) | [Contact Us](#) | [Help](#)

[Change Password](#) [Log Off](#)

[Borrowing Base History](#) [Borrowing Base Posting](#) [Ineligible Report](#) [Ineligible History](#) [Interest Statement](#) [Loan Ledger Report](#) [Loan Status Report](#) **Upload Files** [Upload History](#)

[How to upload files](#) | [How to prepare files for uploading](#) | [Aging file layout specifications](#)

## Upload Supporting Files:

**Max File Size: 10,240 KB**      **Max Combined File Size: 30,720 KB**

### Daily

Adjustment Register:

Cash Register:

Invoice Register:

---

### Monthly

A/P Aging:

A/R Aging:

Client Debtor list:

Financial Statement:

The Upload Files program is used by the borrower to attach the documentation for the borrowing base posting.

The borrower needs to be at a workstation that accesses the company accounting reports.

Please note: The maintenance for the screen is documented on pages 27-29.

# Upload History



Data last updated: Mar 13 2006 09:49:04 (PST) [Privacy Policy](#) | [Contact Us](#) | [Help](#)

[Change Password](#) | [Log Off](#)

[Borrowing Base History](#) | [Borrowing Base Posting](#) | [Ineligible Report](#) | [Ineligible History](#) | [Interest Statement](#) | [Loan Ledger Report](#) | [Loan Status Report](#) | [Upload Files](#) | **Upload History**

## Upload History

[Print](#)

### Daily Files:

Uploaded File	Date
P:\Linda\ar detailing\Orders.prn	3/07/06 11:13:37
P:\Linda\ar detailing\Client.prn	3/07/06 11:13:37

### Monthly Files:

Uploaded File	Date
P:\Linda\ar detailing\march 2005 sample aging.txt	3/07/06 11:13:37

In the Upload History program the borrower can view the history of all the files that have been uploaded in the past

## Other Features

Borrowers are able to change their passwords on-line.

Users are required to change their password the first time they log in.

Borrowers are able to use *Borrowing Base History* to see previously sent Borrowing Bases.

# StuckyNet-Link Component Diagram

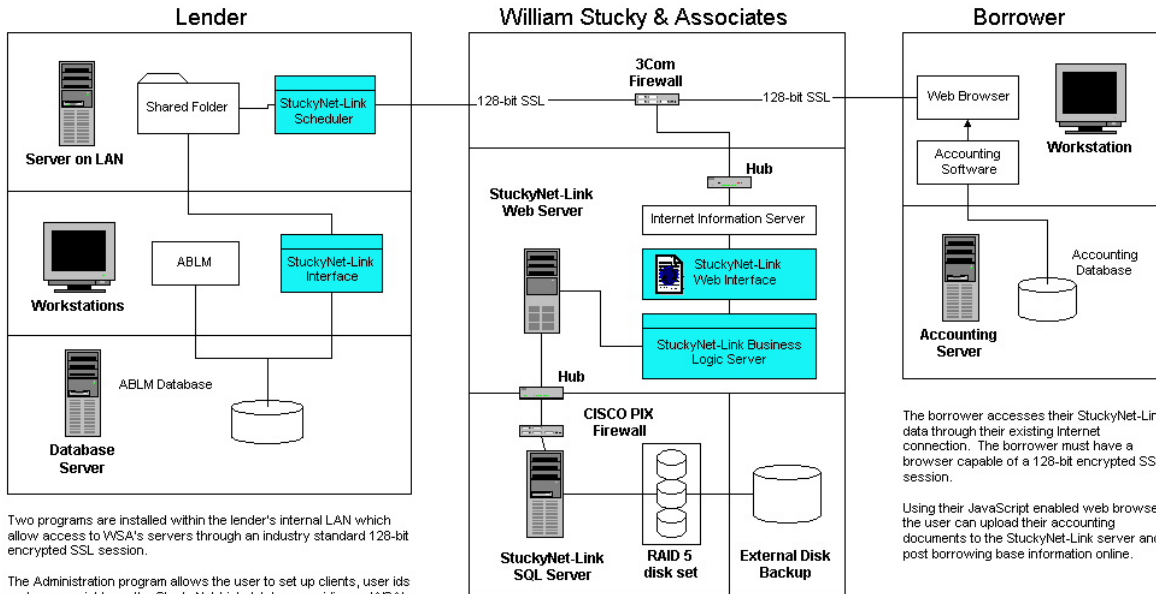

Two programs are installed within the lender's internal LAN which allow access to WSA's servers through an industry standard 128-bit encrypted SSL session.

The Administration program allows the user to set up clients, user ids and access rights on the StuckyNet-Link database residing on WSA's servers.

The Scheduler program runs in the background, downloading files from WSA's servers on a regular basis, and synchronizing data between the lender's ABLM database and their StuckyNet-Link database at WSA.

Files downloaded by the Scheduler are saved to a shared folder on the network. The ABLM Interface program, installed on collateral analyst's and loan officer's desktops, allow the users to view the information from the shared folder on the network, and update postings into the ABLM system.

WSA hosts the lender's StuckyNet-Link database and web interface.

Communication with WSA's StuckyNet-Link servers is accomplished entirely through 128-bit encrypted SSL sessions.

The servers are protected by a dual-firewall system. All Internet traffic is routed through a 3Com firewall appliance which uses stateful packet inspection to protect against Denial of Service, Spoof, and Ping of Death attacks, then through firewall software, configured to allow only traffic from the 3Com appliance.

Running SQL Server and IS on separate machines allows us to create a dual-homed system so that the SQL Server is protected from direct connections to the Internet.

The borrower accesses their StuckyNet-Link data through their existing Internet connection. The borrower must have a browser capable of a 128-bit encrypted SSL session.

Using their JavaScript enabled web browser the user can upload their accounting documents to the StuckyNet-Link server and post borrowing base information online.



# StuckyNet-Link Network Diagram

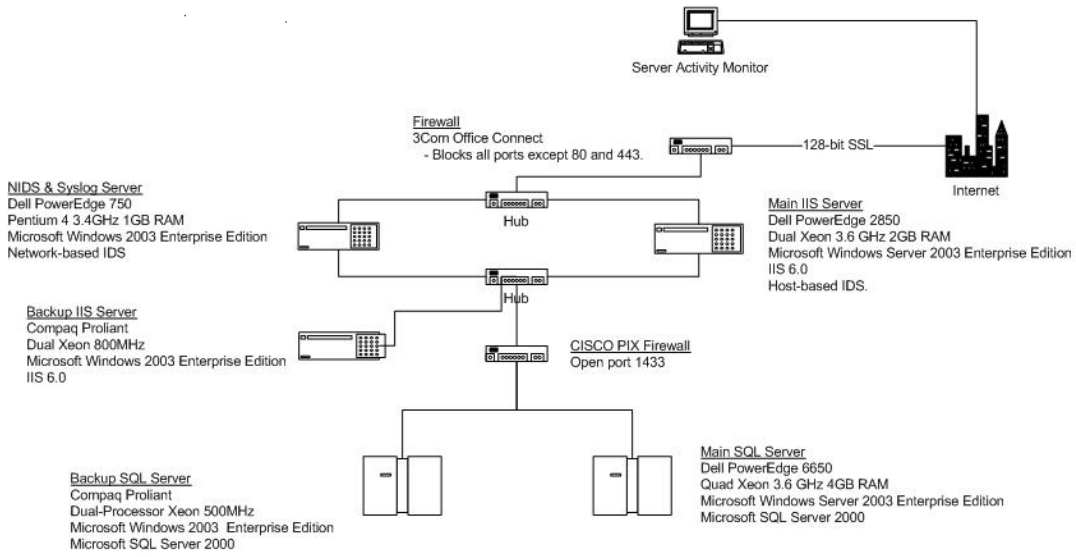

The web interface and business logic server are housed on the IIS Server.

The Server Activity Monitor periodically tests client applications on the IIS Server, to make sure the applications are responding to outside requests.

Client data is stored on the SQL Server, accessible only through an internal IP.

## Features and Security

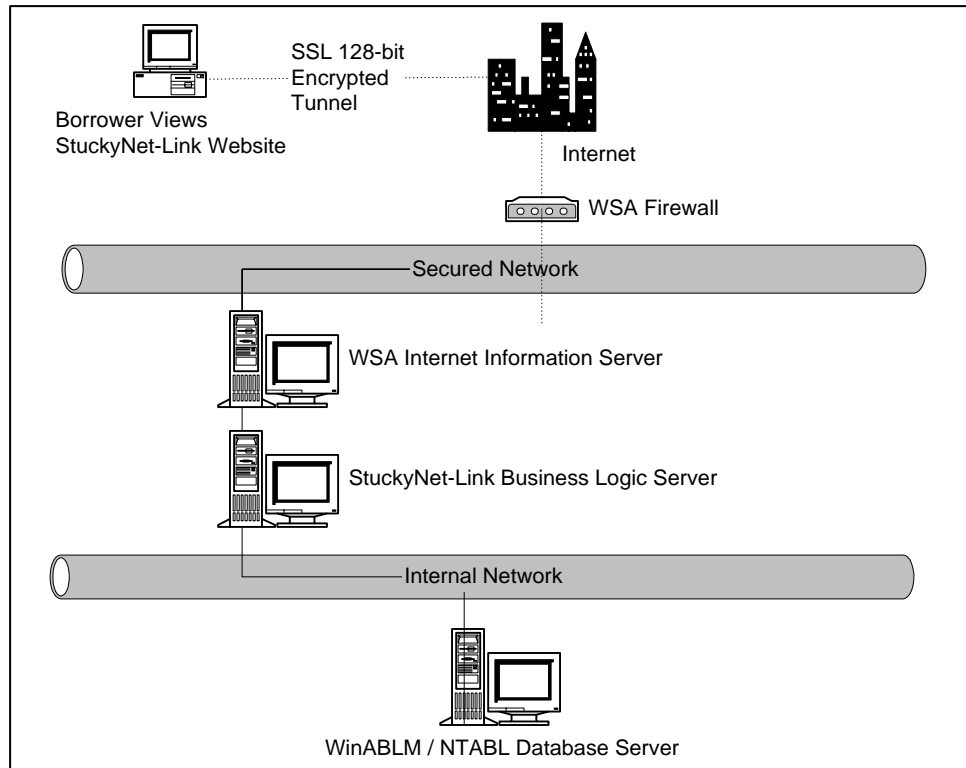

Figure 1. Borrower Link to WSA through StuckyNet-Link Software

### Features

StuckyNet-Link Client is a browser-based program designed to handle the user interface routines. StuckyNet-Link Client communicates with the Business Logic Server via a 128-bit encrypted secure socket layer (SSL) through the Internet. The Business Logic Server then talks to the database server inside a secured network.

**This browser-based solution offers many advantages to both the borrower and the lender:**

- **Real-time user entry validation.** User entries are validated on the client machine using JavaScript, resulting in lighter network traffic and faster response time.
- **More secured communication.** The required 128-bit encryption scheme offers the best Internet security available for e-commerce and other web applications.
- **User-friendly interface.** As computer users are becoming more familiar with the World Wide Web, consistent interfaces encourage ease of use and less technical support.

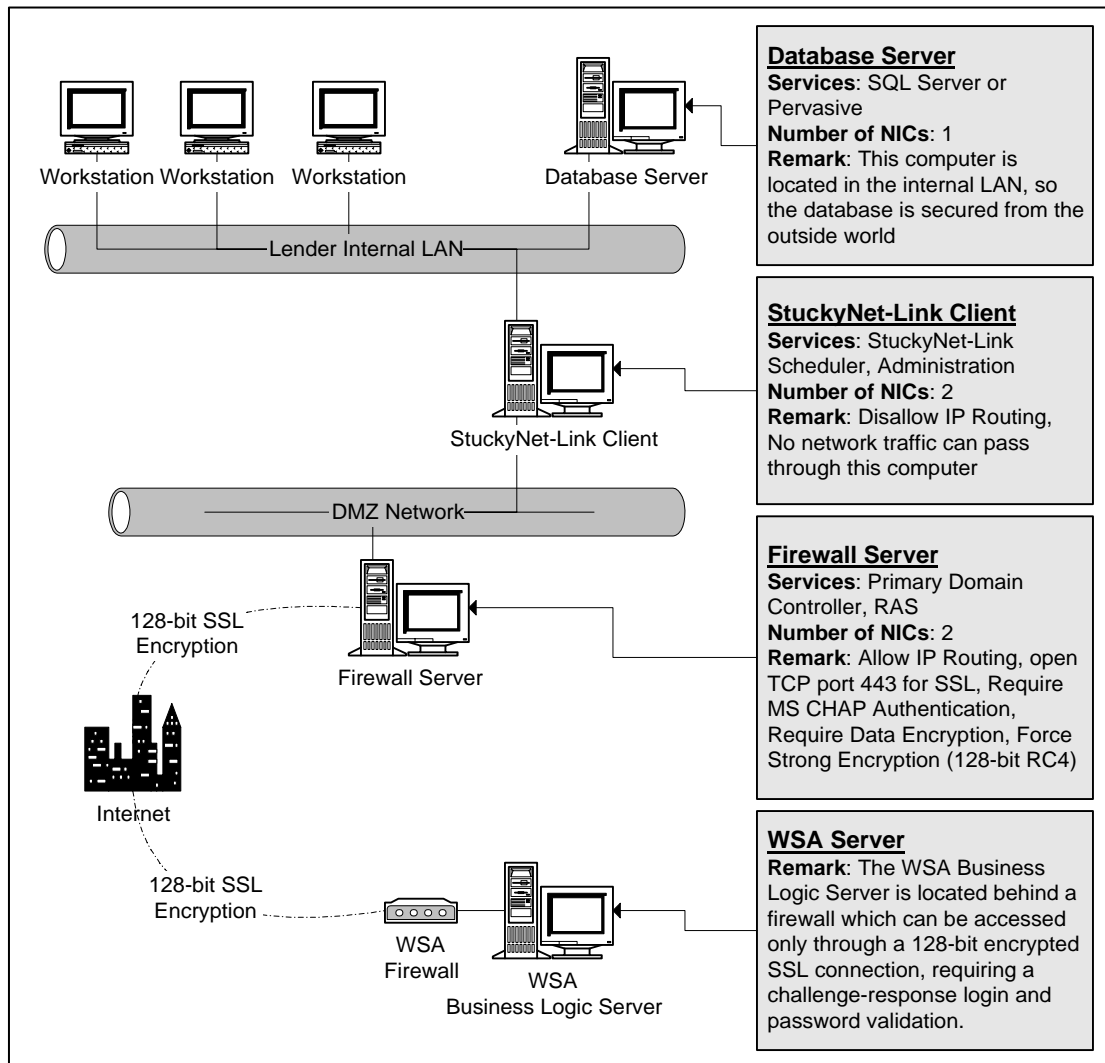

Figure 2. Network Configuration for StuckyNet-Link Lenders.

## Security

The new StuckyNet-Link 3-tier engine and network design pictured in Figure 2 provides many security advantages:

1. Programs transmit data entirely through a 128-Bit encrypted SSL connection to WSA.
2. User authentication is accomplished by a challenge-response password system in the Business Logic Server at WSA.
3. The StuckyNet-Link software installed at the lender site controls the communication between the lender and WSA. The software does not act as an information server; it will only accept information that it has requested

# StuckyNet-Link Administration



## StuckyNet-Link Administration

Please log in to initiate your session:

Client Code

Username

Password

Copyright 2006, [WSA](#). All rights reserved.

The StuckyNet-Link Administration is used by the lender to customize the system and set up borrowers to access StuckyNet-Link. The program is a web application and does not require any software to be installed on your computer.

# StuckyNet-Link Administration

## Client File Maintenance

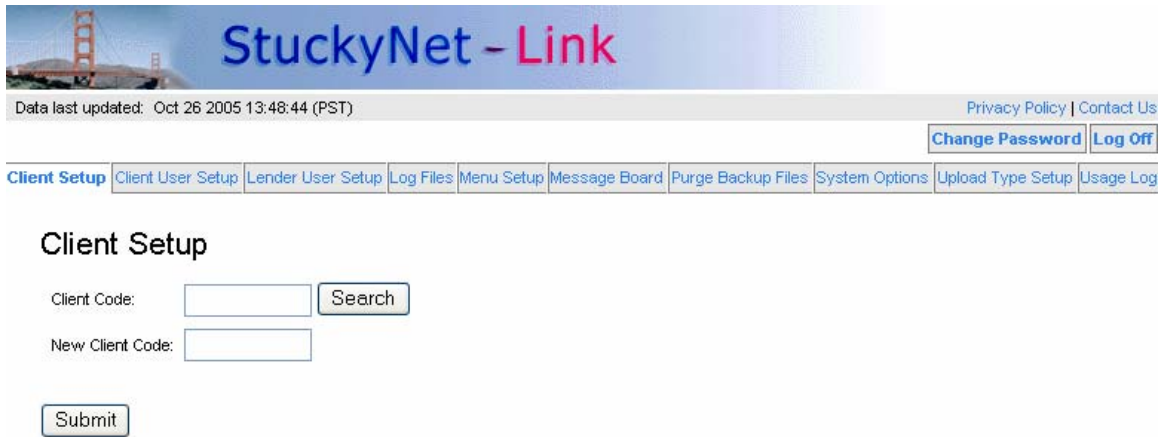

StuckyNet - Link

Data last updated: Oct 26 2005 13:48:44 (PST) [Privacy Policy](#) | [Contact Us](#)

[Change Password](#) [Log Off](#)

[Client Setup](#) [Client User Setup](#) [Lender User Setup](#) [Log Files](#) [Menu Setup](#) [Message Board](#) [Purge Backup Files](#) [System Options](#) [Upload Type Setup](#) [Usage Log](#)

### Client Setup

Client Code:

New Client Code:

Copyright 2005, WSA. All rights reserved.

To set up a client (borrower) to access StuckyNet-Link, enter a new client code, then use SUBMIT button. It is recommended to use the client code from the NT\ABL or WinABLM system. This client code will be displayed on the website when the borrower logs in.

To edit an existing client, select the client code from the drop down box, then use SUBMIT button.

# StuckyNet-Link Administration

## Client File Maintenance

Data last updated: Oct 26 2005 13:48:44 (PST) [Privacy Policy](#) | [Contact Us](#)

[Change Password](#) [Log Off](#)

[Client Setup](#) [Client User Setup](#) [Lender User Setup](#) [Log Files](#) [Menu Setup](#) [Message Board](#) [Purge Backup Files](#) [System Options](#) [Upload Type Setup](#) [Usage Log](#)

### Client Setup

Client Code: AAAA

---

Bank Client

Template ID

Status Code

Branch

Client Name

Comments

Client Code entered on previous page is displayed at top.

Bank Client: Enter the client code from the NT\ABL or WinABLM system. This actually ties the Client Code and Client Login ID to the NT\ABL or WinABLM system.

Template ID: Select the type of template the borrower will be using. Template 1 has the A/R collections default to the loan collections. Template 2, used for borrowers with lockbox accounts, allows the borrowers to enter collections for reporting, but collections do not affect the loan or collateral balance and do not get posted to the ABL system. Customized templates can be programmed on request.

Status Code: Active or Inactive.

Branch: Enter Branch number (optional)

Client Name: Optional

Comment: Optional

# StuckyNet-Link Administration

## Client User File Maintenance

The screenshot shows the StuckyNet-Link Administration interface. At the top, there is a header with the StuckyNet-Link logo and a navigation menu. The navigation menu includes links for Client Setup, Client User Setup (which is highlighted), Lender User Setup, Log Files, Menu Setup, Message Board, Purge Backup Files, System Options, Upload Type Setup, and Usage Log. Below the navigation menu, there is a section titled "Client User Setup". This section contains a form with a "Client Code:" label, an input field, and a "Search" button. Below the input field is a "Submit" button. At the bottom of the page, there is a copyright notice: "Copyright 2005, WSA. All rights reserved."

The Client User File Maintenance is used to setup user IDs for the borrowers.

Select the Client first.

Select User ID from drop down box to edit an existing User ID or enter a new User ID and use the SUBMIT button.

# StuckyNet-Link Administration

## Client User File Maintenance

StuckyNet - Link

Data last updated: Oct 26 2005 13:48:44 (PST) [Privacy Policy](#) | [Contact Us](#)

[Change Password](#) [Log Off](#)

[Client Setup](#) **[Client User Setup](#)** [Lender User Setup](#) [Log Files](#) [Menu Setup](#) [Message Board](#) [Purge Backup Files](#) [System Options](#) [Upload Type Setup](#) [Usage Log](#)

### Client User Setup

**Client Code: AAAA** **User ID: john**

---

Name:

Password:

Status Code:

Department Code:

Regional Format:

Name: Enter user name.

Password: Enter a password for the user. Passwords are required to be between 5 and 10 characters in length and contain both alpha and numeric characters. Passwords are case sensitive. Users are required to change their password upon first login.

Status Code: Select 30-Active or 00-Inactive.

Department Code: Select user department. Departments determine which programs a user has access to. (see page 26 for more information on departments)

Regional Format: Select the location of the user. All dates on the Borrower's site will be displayed based on the regional format setting for the user when the user logs on to the web site.

# StuckyNet-Link Administration

## Lender User File Maintenance



The screenshot shows the StuckyNet-Link Administration interface. At the top, there is a banner with the StuckyNet-Link logo and a background image of the Golden Gate Bridge. Below the banner, there is a navigation menu with the following items: Client Setup, Client User Setup, Lender User Setup (highlighted), Log Files, Menu Setup, Message Board, Purge Backup Files, System Options, Upload Type Setup, and Usage Log. In the top right corner, there are links for Privacy Policy and Contact Us, and buttons for Change Password and Log Off. The main content area is titled "Lender User Setup" and contains two input fields: "User ID:" with a dropdown menu showing "Admin" and "New User ID:" with a text input field containing "Jane". A "Submit" button is located below the input fields.

Copyright 2005, WSA. All rights reserved.

The Lender User File Maintenance is used to setup user IDs for the lender.

Select User ID from drop down box to edit an existing User ID or enter a new User ID and use the SUBMIT button

# StuckyNet-Link Administration

## Lender User File Maintenance

The screenshot shows the StuckyNet-Link Administration interface. At the top, there is a header with the StuckyNet-Link logo and a navigation menu. The main content area is titled "Lender User Setup" and shows the user ID "Jane". Below this, there are several input fields and dropdown menus for configuring the user's profile. The fields are: Name (Jane Williams), Password (masked with dots), Status Code (30-Active), Department Code (900-Lender C/A), and Regional Format (US-Eng). At the bottom of the form, there are "Save" and "Reset" buttons.

StuckyNet - Link

Data last updated: Oct 26 2005 13:48:44 (PST) [Privacy Policy](#) | [Contact Us](#)

[Change Password](#) [Log Off](#)

[Client Setup](#) [Client User Setup](#) [Lender User Setup](#) [Log Files](#) [Menu Setup](#) [Message Board](#) [Purge Backup Files](#) [System Options](#) [Upload Type Setup](#) [Usage Log](#)

### Lender User Setup

User ID: Jane

---

Name:

Password:

Status Code:

Department Code:

Regional Format:

Name: Enter user name.

Password: Enter a password for the user. Passwords are required to be between 5 and 10 characters in length and contain both alpha and numeric characters. Passwords are case sensitive. Users are required to change their password upon first login.

Status Code: Select 30-Active or 00-Inactive.

Department Code: Select user department. Departments determine which programs a user has access to. (see page 26 for more information on departments)

Regional Format: Select the location of the user. All dates on the Administration site will be displayed based on the regional format setting for the user when the user logs on to the site.

# StuckyNet-Link Administration

## Log Files



StuckyNet - Link

Data last updated: Oct 26 2005 13:48:44 (PST) [Privacy Policy](#) | [Contact Us](#)

[Change Password](#) [Log Off](#)

[Client Setup](#) [Client User Setup](#) [Lender User Setup](#) **Log Files** [Menu Setup](#) [Message Board](#) [Purge Backup Files](#) [System Options](#) [Upload Type Setup](#) [Usage Log](#)

### Log Files

File Type:

Date:  ...

Copyright 2005, WSA. All rights reserved.

### Error Log File

Date: 10/06/05

```
08:23:26 clsASP system Verify(Login) Client Code: mega, UserID: linda Login Failed. Error message:
08:23:54 clsASP system Verify(Login) Client Code: spti, UserID: linda Login Failed. Error message:
08:24:01 clsASP system Verify(Login) Client Code: spti, UserID: linda Login Failed. Error message:
08:24:08 clsASP system Verify(Login) Client Code: spti, UserID: theresa Login Failed. Error message:
08:24:51 clsASP system Verify(Login) Client Code: spti, UserID: linda Login Failed. Error message:
08:25:07 clsASP system Verify(Login) Client Code: spti, UserID: theresa Login Failed. Error message:
08:26:52 clsASP system Verify(Login) Client Code: spti, UserID: linda Login Failed. You have excee
08:50:24 clsScheduler linda bLogin User: linda 0
```

Log Files are used by system administrators to view activity on the site. The log files are created by the program that runs the website and are meant to track activity on the site and allow system administrators easy access.

If no data is displayed for a particular date, that means there was no activity or errors on that date.

# StuckyNet-Link Administration

## Menu File Maintenance



StuckyNet - Link

Data last updated: Oct 26 2005 13:48:44 (PST) [Privacy Policy](#) | [Contact Us](#)

[Change Password](#) [Log Off](#)

[Client Setup](#) [Client User Setup](#) [Lender User Setup](#) [Log Files](#) **Menu Setup** [Message Board](#) [Purge Backup Files](#) [System Options](#) [Upload Type Setup](#) [Usage Log](#)

### Menu Setup

Dept ID:

New Dept ID:

Copyright 2005, WSA. All rights reserved.

Menu File Maintenance is used to setup department and menu structures. Lenders are able to setup as many departments as needed. Users are assigned to departments and only have access to the programs included in the department setup. The system comes with four departments already setup. In the above screen, select the Dept. ID to be modified, or to create a new dept. enter a new number. Borrowers can be 500-799, and lenders can be 800-999.

Dept. #	Department Name
500	Borrower Inquiry Only
799	Borrower Maximum Access
900	Lender C/A
999	Administrators

# StuckyNet-Link Administration

## Menu File Maintenance

### Menu Setup

Dept ID: 600

---

Department Name

Menu Options:

Interest Statement  
Ineligible Report  
Upload History  
Upload Files

Add =>

<= Remove

Department Menu:

Borrowing Base Posting  
Borrowing Base History  
Ineligible/Reserve Inquiry  
Loan Ledger Report  
Loan Status Report

Department ID 500 – Borrower Inquiry only is displayed above.

Menu Options – lists the programs available but not included in the department menu

Department Menu – lists the programs included in the department’s menu structure.

To ADD a program to the department menu, highlight the program in the Menu Options list, and then use the ADD button.

To REMOVE a program from the department menu, highlight the program in the Department Menu and use the REMOVE button.

# StuckyNet-Link Administration

## System Options



Data last updated: Oct 26 2005 13:48:44 (PST) [Privacy Policy](#) | [Contact Us](#)

[Change Password](#) [Log Off](#)

[Client Setup](#) [Client User Setup](#) [Lender User Setup](#) [Log Files](#) [Menu Setup](#) [Message Board](#) [Purge Backup Files](#) **System Options** [Upload Type Setup](#) [Usage Log](#)

### System Options

Program Name: DemoNT\_2\_8\_10a version: 2.8.10

**Modifying any of the following settings will affect the entire website. Please use caution when changing these settings.**

Paths	
Logo	<input type="text" value="images/snlgif"/>
StyleSheet	<input type="text" value="style.css"/>
Options	
Verisignimg	<input type="text" value="images/verisign_logo.gif"/>
VerisignAnchor	<input 856de3e7a4f431034fc08865d9aa2551"="" as2="" digitalid.verisign.com="" https:="" type="text" value="&lt;a href="/>
Slogan	<input type="text" value="Powered by WSA"/>
Title	<input type="text" value="StuckyNet-Link - Online Asset Based Lending"/>
StdMeta	<input &gt;&lt;meta="" co"="" content="no-cache" name="ROBOTS" pragma"="" type="text" value="&lt;meta http-equiv="/>
WebmasterNotice	<input type="text" value="&lt;CENTER&gt;An error has occurred while processing your request.&lt;BR&gt;Please try"/>
Footer	<input a&gt;.="" all="" http:="" reserved"="" rights="" type="text" value="Copyright 2005, &lt;a href=" www.stuckynet.com"&gt;wsa&lt;=""/>
HTML	
WarningFont	<input type="text" value="&lt;font color=red size=+1&gt;"/>
MandatoryColor	<input type="text" value="#9FD1F7"/>
ContentsBackColor	<input type="text" value="#E7E7E7"/>
Admin	
SupportRep	<input type="text"/>
Password	
ExpirationDays	<input type="text" value="60"/>
MinLength	<input type="text" value="7"/>
AlphaRequired	<input type="text" value="true"/>
NumericRequired	<input type="text" value="false"/>
Custom	
Header	<input type="text" value="header.txt"/>
TrackSyncTimes	<input type="text" value="false"/>
KeepLogDays	<input type="text" value="2"/>
UserRgnFormat	<input type="text" value="US-Eng"/>
BLS	
DateFormat	<input type="text" value="mm/dd/yy"/>

The system options form allows administrator to customize some of the website.

Changes made on this screen affect all subsequently loaded pages for all users. For this reason, only administrators of the system should change these settings after contacting and verifying any changes with WSA.

# StuckyNet-Link Administration

## File Type Upload

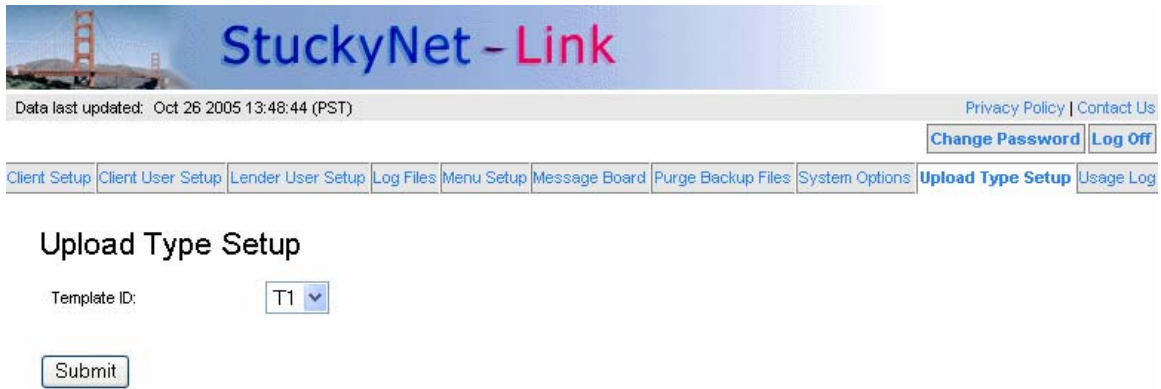

The screenshot shows the StuckyNet-Link Administration interface. At the top, there is a banner with the Golden Gate Bridge and the text "StuckyNet - Link". Below the banner, a status bar indicates "Data last updated: Oct 26 2005 13:48:44 (PST)" and provides links for "Privacy Policy" and "Contact Us". A navigation menu includes "Client Setup", "Client User Setup", "Lender User Setup", "Log Files", "Menu Setup", "Message Board", "Purge Backup Files", "System Options", "Upload Type Setup" (which is highlighted), and "Usage Log". Below the navigation menu, the "Upload Type Setup" page is displayed. It features a "Template ID:" label, a dropdown menu with "T1" selected, and a "Submit" button.

Copyright 2005, WSA. All rights reserved.

The File Type Upload Maintenance is used by the lender to set up the file types to be submitted by the borrower. First select the template ID to be modified. Files types are determined by template.

Template 1 – A/R collections default to loan collections.

Template 2 – Collections on A/R and loan are memo only

Template 3 – A/R collections and loan collections are posted separately.

Please note: Templates are assigned to borrowers (clients) in the Client File Maintenance.

# StuckyNet-Link Administration

## File Type Upload

### Upload Type Setup

Template ID: T1

Type:

New Type:

- AP
- AR
- AdjReg
- CashReg
- FinStmt
- InvReg

To edit an existing file type, select it from the drop down box. To set up a new file type, enter it in the new type box.

### Upload Type Setup

Template ID: T1      Type: Inventory

---

Description:

Abbreviation:

Frequency:

Description: Enter a file type description.

Abbreviation: Enter a file type abbreviation. The abbreviation combined with the date sent will be the file name when it is sent through the scheduler.

Frequency: Select *Daily* or *Monthly*.

# StuckyNet-Link Administration Usage Log

The Usage Log is used to view activity on the Borrowers site, Administration site and Scheduler.

StuckyNet - Link

Data last updated: Oct 26 2005 13:48:44 (PST) [Privacy Policy](#) | [Contact Us](#)

[Change Password](#) [Log Off](#)

[Client Setup](#) [Client User Setup](#) [Lender User Setup](#) [Log Files](#) [Menu Setup](#) [Message Board](#) [Purge Backup Files](#) [System Options](#) [Upload Type Setup](#) **Usage Log**

### Usage Log

Program:  ▼

From Date:  ...

To Date:  ...

Copyright 2005, WSA. All rights reserved.

## Usage Log

Activity Dates: 11/03/05 to 11/03/05

Date	Time	Program	User ID	Action
11/03/05	1:50:53 PM	Administer		Timed Out
11/03/05	1:53:33 PM	Administer	admin	Admin Login
11/03/05	1:54:20 PM	Administer	admin	Log Out
11/03/05	1:54:25 PM	Administer	admin	Admin Login
11/03/05	1:56:31 PM	Administer	admin	Log Out
11/03/05	1:56:35 PM	Administer	admin	Admin Login
11/03/05	1:57:08 PM	Administer	admin	Admin Login
11/03/05	1:57:24 PM	Administer	admin	Admin Login
11/03/05	1:57:39 PM	Administer	admin	Log Out

# StuckyNet-Link Administration

## Change Password

The screenshot shows the StuckyNet-Link Administration interface. At the top, there is a banner with the Golden Gate Bridge and the text "StuckyNet - Link". Below the banner, a status bar indicates "Data last updated: Oct 26 2005 13:48:44 (PST)" and provides links for "Privacy Policy" and "Contact Us". A navigation menu includes "Change Password" and "Log Off". A secondary menu contains various administrative options: "Client Setup", "Client User Setup", "Lender User Setup", "Log Files", "Menu Setup", "Message Board", "Purge Backup Files", "System Options", "Upload Type Setup", and "Usage Log". The main content area is titled "Change Password" and contains a form with the following fields: "User Name" (pre-filled with "admin"), "Old Password", "New Password", and "Confirm New Password". A "Change Password" button is located at the bottom of the form.

Copyright 2005, WSA. All rights reserved.

The change password option allows the user to change their password.

Users are required to change their password the first time they login to StuckyNet-Link.

## LogOff

Use the log off function to end your secure StuckyNet-Link session.

# StuckyNet-Link Interface Program

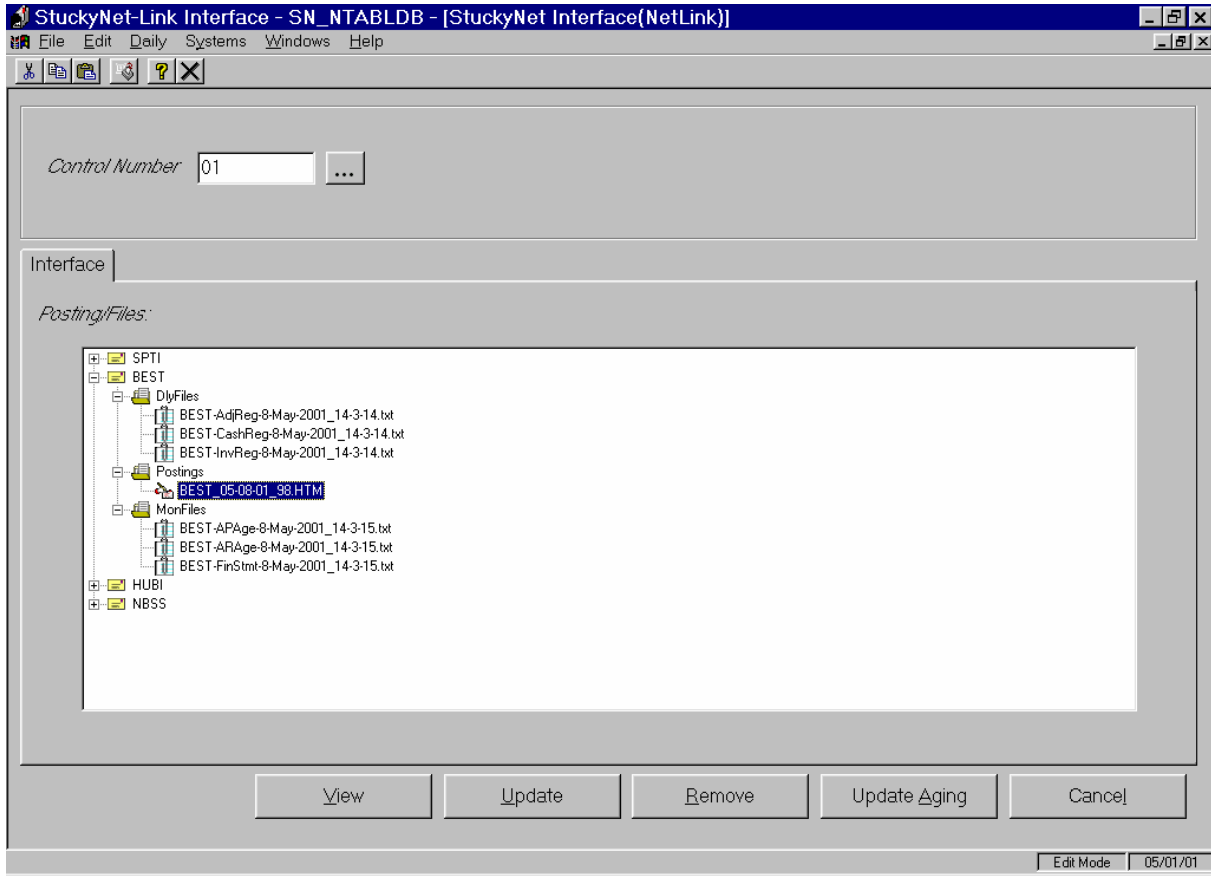

StuckyNet-Link Interface program accesses the borrowing base postings and files that have been sent to the lender. The collateral analyst is selected from the analyst Rolodex. Then the clients assigned to the selected collateral analyst are displayed. The folders contain all new the daily files, borrowing base postings and monthly files.

Workflow – The collateral analyst will want to view the BBP and supporting documentation. Therefore, the BBP will be viewed, the sales and collection journals will be viewed and then the BBP will be updated to your Stucky NTABL or WinABLM or removed.

To accept the BBP and post it to your Stucky NTABL or WinABLM system, use the *UPDATE* button. To reject the BBP, use the *REMOVE* button.

To “file” the supporting documentation for the borrower, use the *REMOVE* button. The file is moved from the Interface to Historical Records. A copy is also saved on the lender server for back-up.

A context menu is available by right clicking on each item.

# StuckyNet-Link Interface Program Historical Records

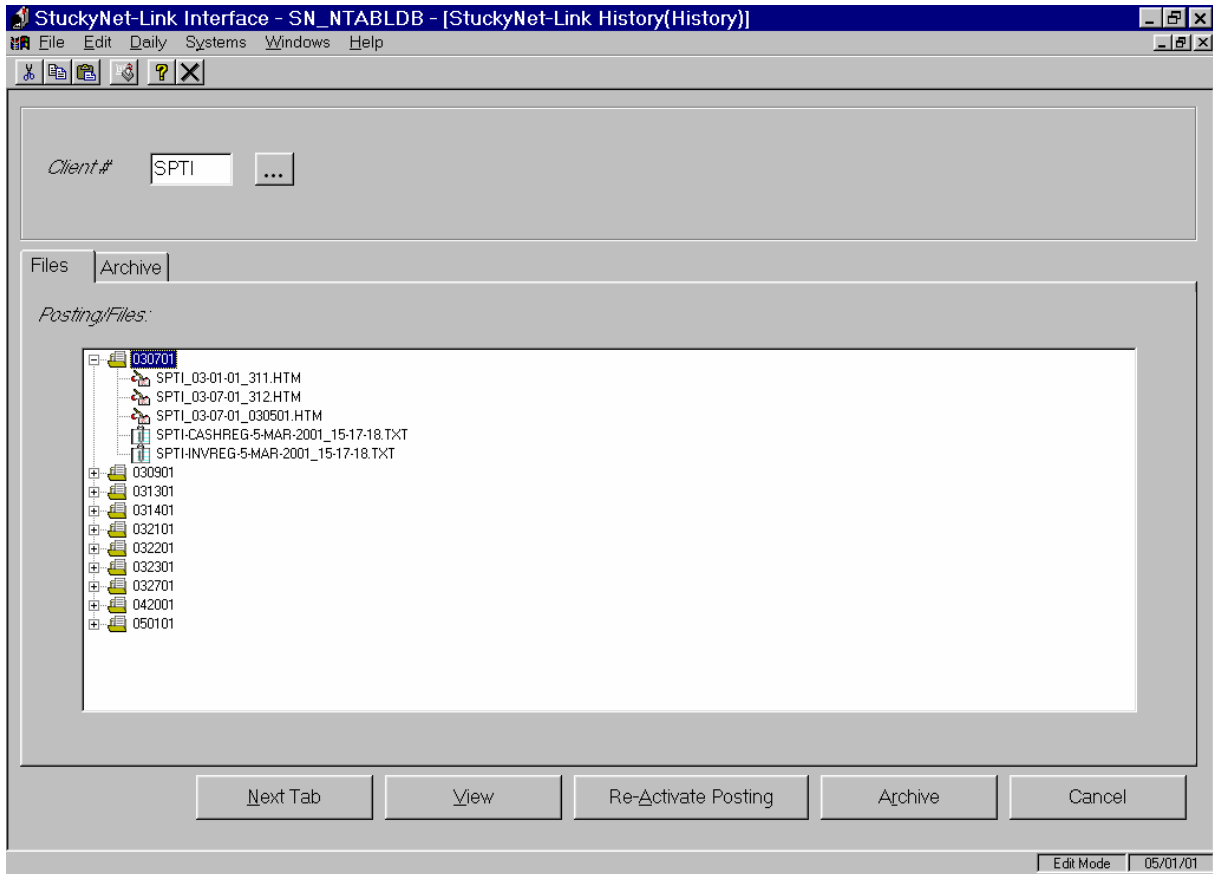

Supporting documentation can be viewed and BBPs that have been removed can be reactivated. The historical records program allows easy access to files that have already come through the system. Files are organized by client number and date, and can be reactivated and sent back to the interface program for reprocessing.

Folders can be archived when no longer useful, and still be accessible through the archive program.

# StuckyNet-Link Scheduler Program

The StuckyNet-Link Scheduler is used to control the transfer of information and data between the lenders and borrowers. Recurring tasks can be setup to run automatically or the processes can be done on demand.

The four processes of the StuckyNet-Link Scheduler are:

- Synchronize Data
- Download Postings
- Download Daily Files
- Download Monthly Files

**Synchronize Data** – Synchronizes the data from the NT-ABL or WinABLM system to the StuckyNet-Link database. It is important to synchronize the data after any postings are made to the NT-ABL or ABLM system. The data must be synchronized for the client to see the most up-to-date information.

**Download Postings** – Downloads borrowing base postings that have been sent by the borrowers. After the scheduler has downloaded the postings, the postings are accessed in the StuckyNet-Link Interface.

**Download Daily Files** – Downloads daily files. Daily files will consist of sales register, collection register, adjustment register, inventory listings and any other files that need to be transferred on a daily basis.

**Download Monthly Files** - Downloads monthly files. Monthly files will consist of A/R agings, A/P agings, financial statements and any other files that need to be transferred on the monthly basis.

When the Scheduler is minimized it runs in the background, but users will not be prompted with any messages or status bar displays.

The Scheduler can be set up to load on startup.

# StuckyNet-Link Scheduler Program

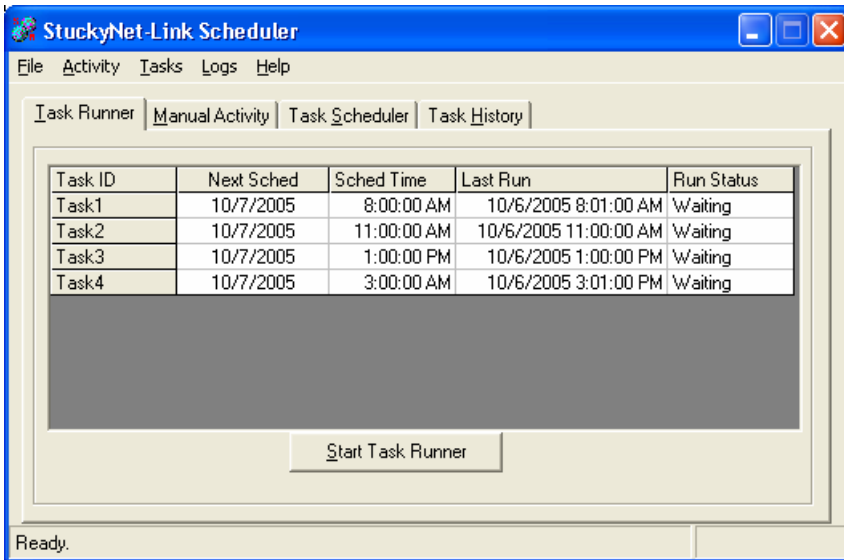

The *Task Runner* tab displays the scheduled tasks and status.

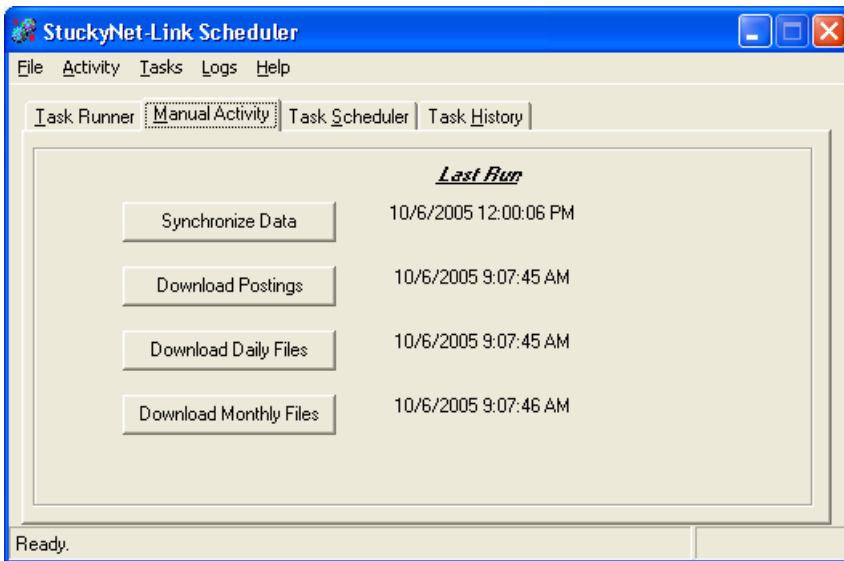

The Manual Activity tab in the program allows each of the process to be run on demand. To perform one of these processes, use the button.

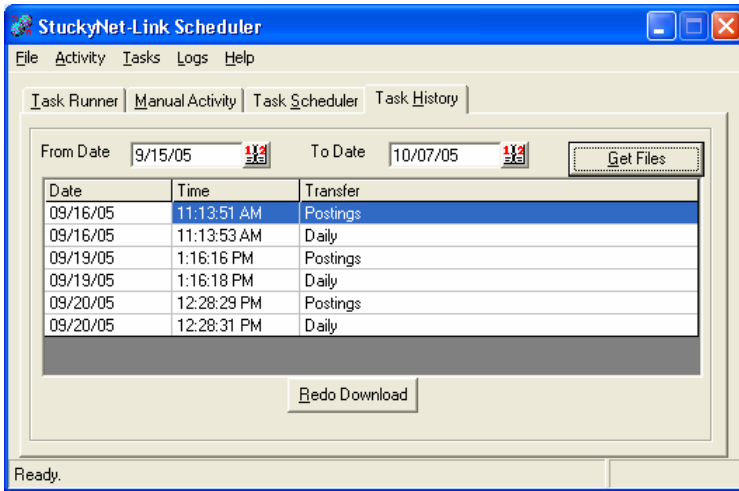

The Task History tab displays completed processes for dates selected. Selected files can be downloaded from the StuckyNet-Link server and reactivated for use in the Interface program.

# StuckyNet-Link Scheduler

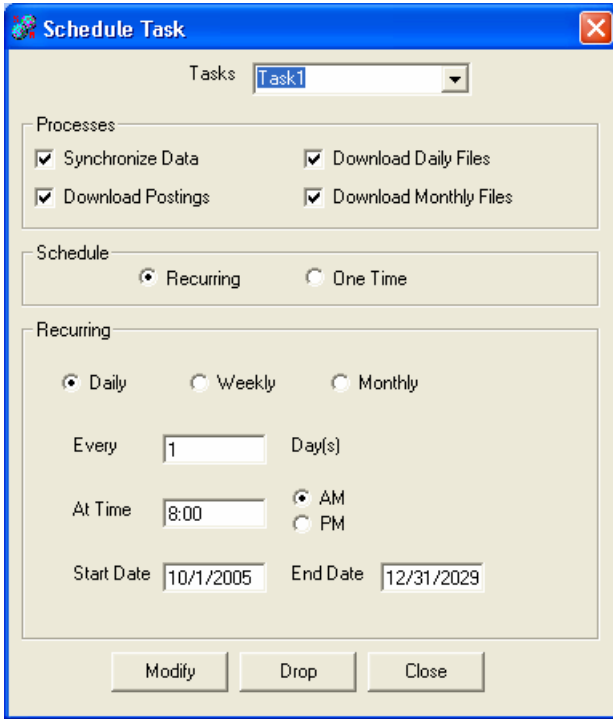

The *Schedule Task* tab is used to schedule new tasks or edit existing ones. To schedule a task, use the *Schedule Task* button and the above dialog box will open.

Type in the name of the task (task 1, 2 etc. or morning task, etc.). Then check the processes to be completed in the task. Select one time or recurring. If the task is recurring, complete the recurring information files.